



Available at:



NC-1W Condensate Neutralizer Technical Information

DIMENSIONS:

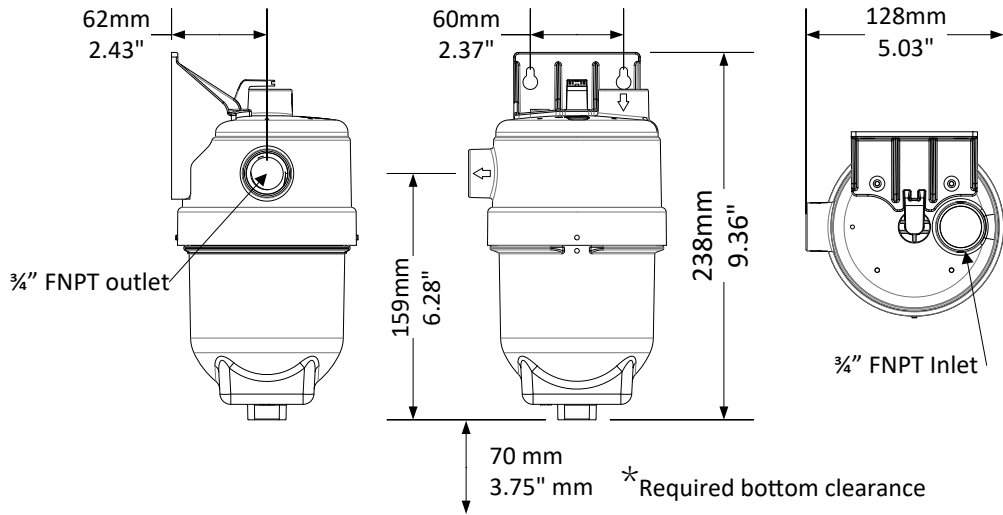

WEIGHT: 1.7 kg, 3.7 lbs. (dry weight with Media)

Bottom Clearance: 70mm [3.75"]

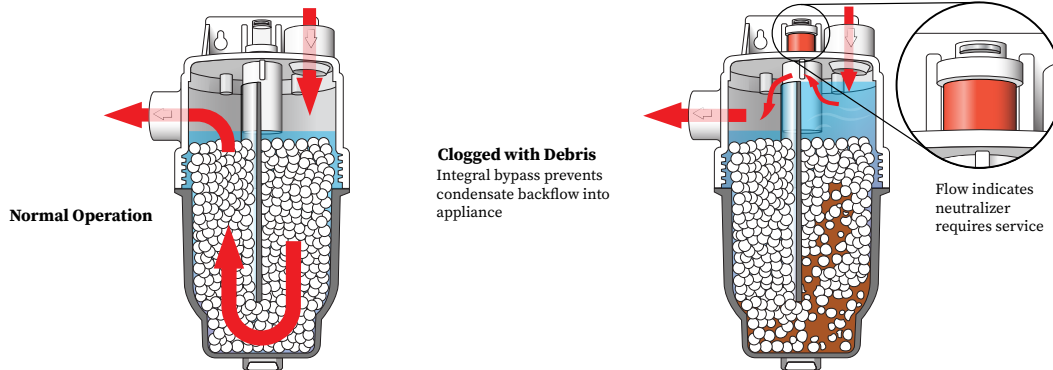

SPECIFICATION:

The wall hung condensate neutralization capsule shall be AXIOM INDUSTRIES LTD. model NC-1W. System shall include 1 litre (0.26 U.S. gallon) capsule with integral by-pass overflow baffle wall made from corrosion resistant materials with one 4" fill/access openings, 3/4"-14 FNPT threaded inlet and outlet, manual reset by-pass flow indicator (Polyurethane float and Neodymium magnet), and wall mounting bracket.

OPTIONAL ACCESSORIES:

- NM-1** -- Replacement LipHter⁺ neutralization media (Exact Refill)
- NM-1BULK** -- Replacement LipHter⁺ neutralization media (Up to 15 Refills)

LIMITED WARRANTY:

The "NC-1W" is warranted against defects in materials and workmanship for one year.



Project _____
 Consultant _____
 Unit Tag _____

Location _____
 Contractor _____
 Sales Agent _____