

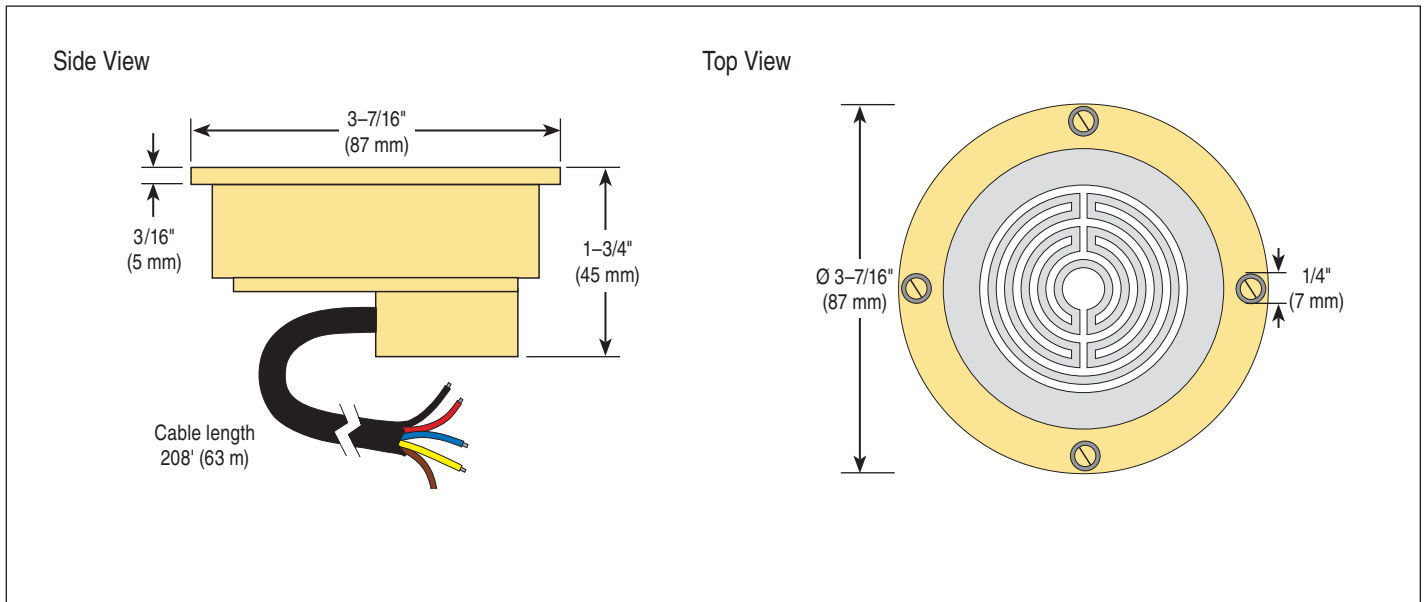

Job _____ Designer _____ Contact _____

The Snow/Ice Sensor 094 is an in ground sensor used with tekmar snow melting controls to automatically detect snow or ice on a driveway or walkway. The 094 has 208 ft. (63 m) of wire. This product can be used in applications ranging from residential driveways to commercial building fronts such as emergency access entries. This sensor allows tekmar snow melting controls to automatically operate the snow/ice melt system only when snow or ice is present, while also providing temperature feedback to the control.



Specifications

Snow / Ice Sensor 094 In-slab, 208 ft. (63 m) Wire	
Literature	090_D, 094_C
Packaged weight	10.4 lb (4762 g)
Dimensions	1-3/4" H x 3-7/16" OD (45 mm H x 87 mm OD)
Sensor material	Silicon brass
Cable Material	208 ft. (63 m) 5 conductor stranded wire with polyethylene jacket
Approvals	CSA C US
Operating range	-30 to 170°F (-34 to 77°C)
Load rating	15,000 lb (66,723 N) distributed load, non-impact, installed in concrete according to the manual
Included	4 #4-40, 7/16" machined, stainless steel screws 4 #6-32, 3/8" flathead, slotted, stainless steel screws
Warranty	Limited 3 Year (See 090_D for full warranty)

Energy Saving Features

- Automatic snow/ice detection so melting systems only operate when needed

Additional Features

- Slab temperature reading
- Long wire included so in field splicing is not necessary
- Designed for long life in driveway and walkway installations
- 208 ft. (63 m) of cable

SPECIAL REQUIREMENTS

The Snow / Ice Sensor 090 must be operated by a tekmar Snow Melting Control 654, 661, 662, 664, 665, 667 or 680. Operation of the sensor by 3rd party control systems may result in electrolysis failures not covered by the tekmar Limited Warranty.



tekmar Control Systems Ltd., A Watts Water Technologies Company. Head Office: 5100 Silver Star Road, Vernon, B.C. Canada V1B 3K4, 250-545-7749, Fax. 250-984-0815 Web Site: tekmarControls.com

