

Submittal

Job _____ Designer _____ Contact _____

Invita® WiFi Thermostat 564

The Invita WiFi Thermostat makes upgrading easy by using the existing 2-wires from any living space to connect to an HVAC Interface Module in the mechanical room. It works with most types of heating and cooling systems including conventional, heat pump and dual fuel while offering fan, relative humidity and ventilation control. The Invita Connect app provides secure WiFi adjustment, and can send email notifications when there are problems with the HVAC system. The Invita WiFi Thermostat is available in both white and black finishes and offers a choice of five display screen color themes.

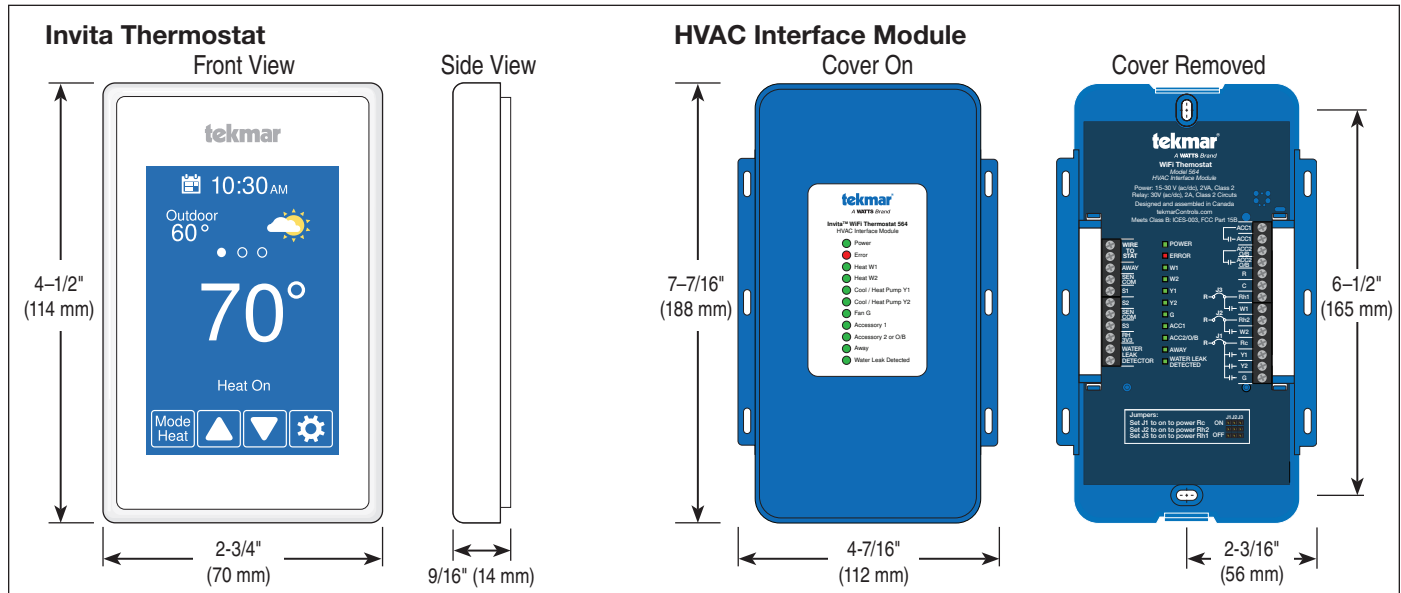

Specifications

Invita WiFi Thermostat 564 <i>The WiFi thermostat that only uses two wires.</i>	
Literature	Submittal, Installation and Operation Manual, User Manual, Job Record
Packaged weight	1.3 lb. (600 g)
Dimensions	Display: 4-1/2" H x 2-3/4" W x 9/16" D (114 x 70 x 14 mm) HVAC Interface Module: 7-7/16" H x 4-7/16" W x 1-1/4" D (188 x 112 x 31 mm)
Display	3.5" color touchscreen
Enclosure	Display: White or Black PVC plastic, NEMA type 1 HVAC Interface Module: Blue PVC plastic, NEMA type 1
Approvals	Meets Class B: ICES & FCC Part 15
Ambient conditions	Display: -4 to 122°F (-20 to 50°C), RH ≤90% non-condensing HVAC Interface Module: -40 to 122°F (-40 to 50°C), RH ≤90% non-condensing, outdoor use requires mounting in a NEMA 3 enclosure
Environmental	Do not use in presence of ammonia such as animal barns
Power supply	21 to 30 V (ac), 6 VA, Class 2
Relays	30V(ac), 2 A, Class 2 Circuits
Humidity sensor	0 to 90% ±4% RH
Temperature sensor	NTC thermistor, 10 kΩ @ 77°F (25°C ±0.2°C) β=3892
Optional sensors	tekmar type # 070, 072, 073, 076, 077, 079, 084, 086, 087
Communications	WiFi 802.11n, 2.4 GHz, WPA2 encryption
Mobile app	Apple iOS 12 or higher, Android 10 or higher
Languages	English/Français/Español
Warranty	3 Year Limited Warranty

tekmar product specifications in U.S. customary units and metric are approximate and are provided for reference only. For precise measurements, please contact tekmar Technical Service. Watts reserves the right to change or modify product design, construction, specifications, or materials without prior notice and without incurring any obligation to make such changes and modifications on tekmar products previously or subsequently sold.

Works with

Conventional systems

- 2-stage heating, 2-stage cooling, fan and 2 accessories

Heat pump & dual fuel systems

- 4-stage heating, 2-stage cooling, fan, reversing valve and 1 accessory

Accessory options

- Humidifier, dehumidifier, HRV/ERV ventilator

Features

- Mobile app for iOS and Android
- Email notifications with option for alerts from Watts FloodSafe® Water Detector Shutoff
- Weather and outdoor temperature display
- Programmable schedule with early start
- Energy usage reports
- Relative humidity
- Ventilation
- Away energy saving mode
- 3 auxiliary sensor inputs
- Choice of black or white finish
- Multiple display colors
- Slim, 9/16" profile
- Wall trim plate included

Example Application

Sample Mechanical diagram

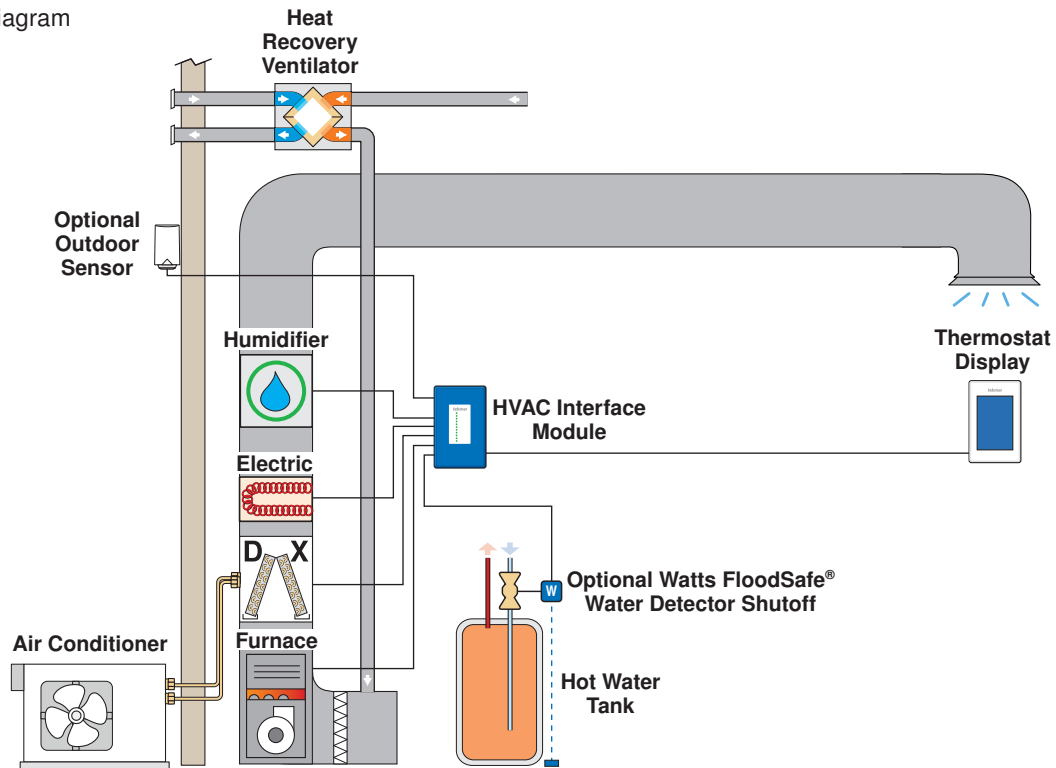

Sample Electrical diagram

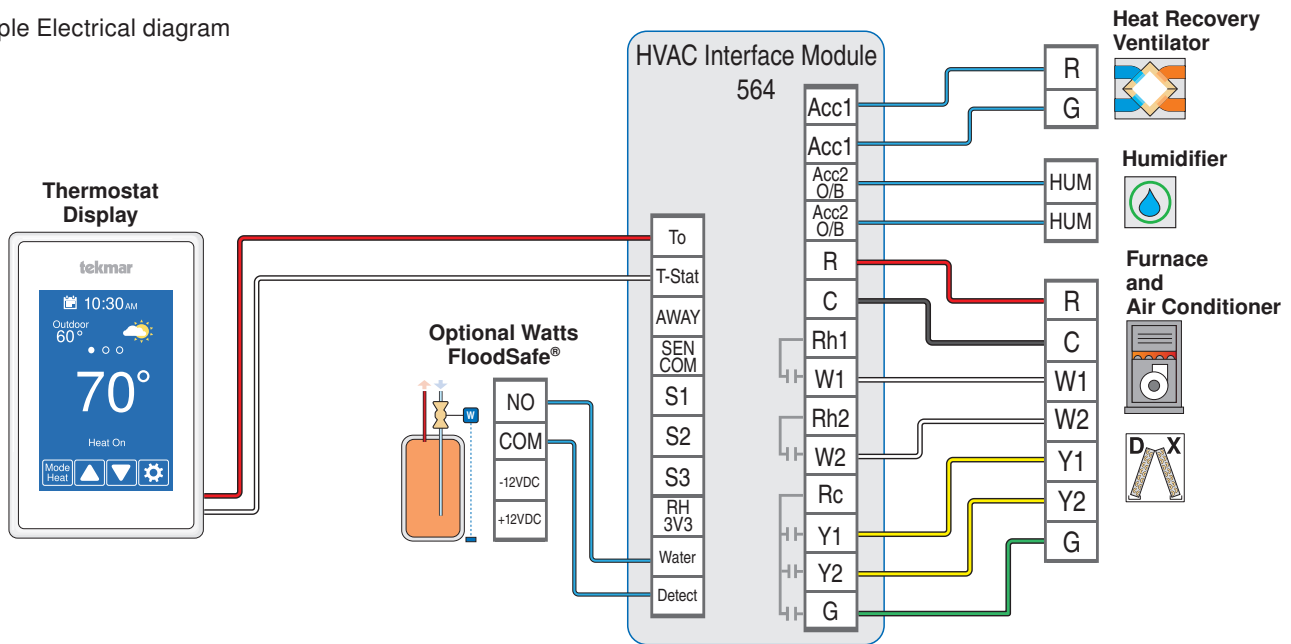

NOTICE

The information contained herein is not intended to replace the full product installation and safety information available or the experience of a trained product installer. You are required to thoroughly read all installation instructions and product safety information before beginning the installation of this product.



A WATTS Brand