

For Residential and Commercial Applications

Job Name _____

Contractor _____

Job Location _____

Approval _____

Engineer _____

Contractor's P.O. No. _____

Approval _____

Representative _____

Model RBFF

Residential Boiler Fill Fitting

Size: 1/2" (15mm)

Model RBFF Residential Boiler Fill Fitting provides a convenient solution to comply with boiler manufacturers' piping requirements and provide ease of service for expansion tanks and water pressure regulator valves in closed-loop hot water heating systems. Using a unique 3-way ball valve design, the RBFF eliminates up to twelve 1/2 inch fittings in a compact package.

Features

- One-piece construction, eliminating up to 11 threaded joints
- Unique 3-way ball valve for isolation of water pressure regulator and expansion tank from system pressure
- Drain port with integral ball valve for unloading pressure from waterside of expansion tank diaphragm for air charge servicing and maintenance. Drain port can also be used for a variety of system draining and filling operations.
- 0 to 30psi (0 to 87kPa) pressure gauge for convenient system pressure reference

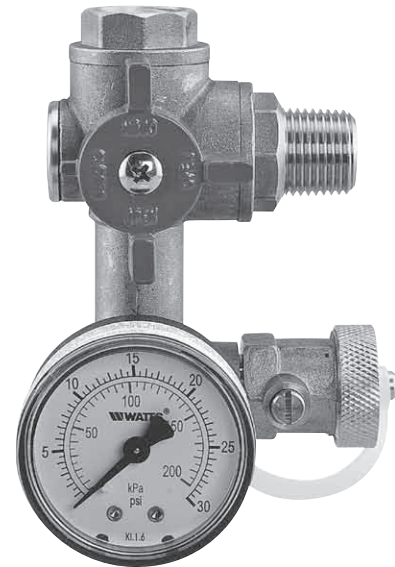

RBFF

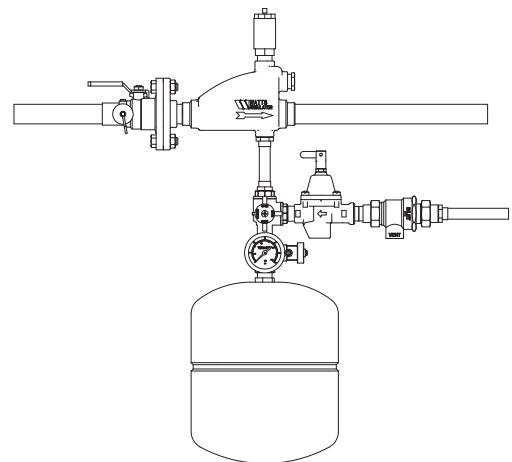

Fig. 1

Available at: 631-240-9173

PEXHEAT.COM

Watts product specifications in U.S. customary units and metric are approximate and are provided for reference only. For precise measurements, please contact Watts Technical Service. Watts reserves the right to change or modify product design, construction, specifications, or materials without prior notice and without incurring any obligation to make such changes and modifications on Watts products previously or subsequently sold.

WATTS®

Specifications

A combination isolation/drain valve with pressure gauge shall be installed where indicated on the plans. The valve shall facilitate the servicing and/or replacement of the diaphragm expansion tank by providing the ability to isolate the tank from system pressure and unload pressure from the waterside of the diaphragm. The isolation/drain valve shall also provide isolation of the water pressure regulator valve from system pressure for the purpose of servicing and/or replacement. The isolation/drain valve shall be a Watts Model RBFF.

Materials

Body – Brass

Ball – Plated Brass

Seats – Virgin PTFE

Pressure - Temperature

Maximum Inlet Temperature – 250°F (121°C)

Maximum Working Pressure – 125psi (860 kPa)



A Watts Water Technologies Company

Available at:

PEXHEAT.COM



ISO 9001-2000
CERTIFIED