



Available at: 888-470-2757

PEXHEAT.COM

## MF200 HYDRONIC SYSTEM FEEDER TECHNICAL INFORMATION

### DIMENSIONS :

**WEIGHT :** 5.4 kg 12 lbs

\* Weight When Full 60 lbs/ 27kg Discharge

### PUMP ELECTRICAL :

Rated 50 watts

UL listed AC/DC power supply adapter

100-240 VAC/50-60 Hz/1 to 24 VDC

### PUMP PERFORMANCE :

0.04 l/m (1.0 gpm) @ free flow

Self-priming up to 1.2 m (4 feet)

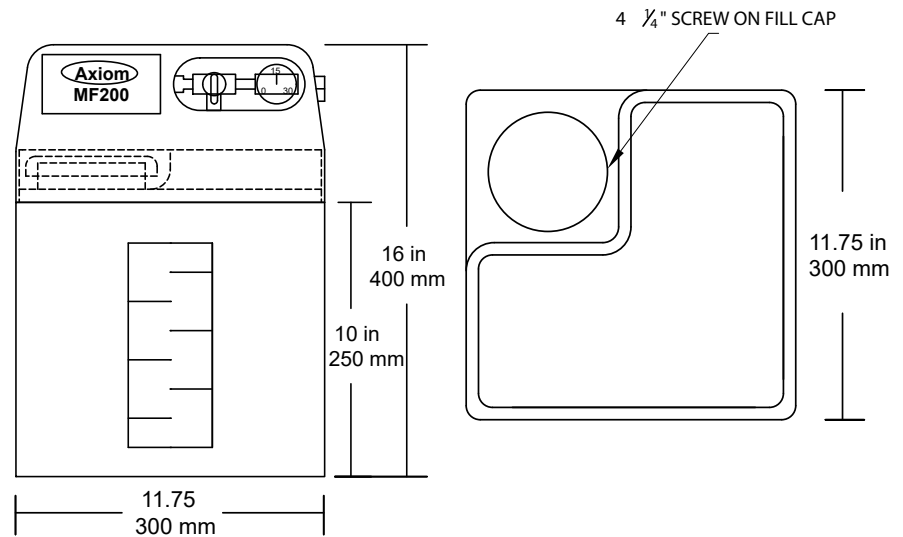

### CLEARANCES :

Depth -- 11.75 in (300 mm)

Clearances -- Right side and Top - 12 in 305 mm

System Connection -- 1/2" FPT

### SPECIFICATION :

Hydronic system feeder shall be AXIOM INDUSTRIES LTD. Model MF200. System shall include 25 litre (6.0 U.S. gallon) storage/mixing tank with molded-in liquid level gauge, 100 mm (4") fill/access opening and cover; pump suction hose with inlet strainer; check valve; pressure pump with fuse protection; low fluid level pump cut-out float switch; manual diverter valve for purging air and agitating contents of storage tank; pressure switch with snubber, adjustable from 70 kPa (10 psig) to 170 kPa (25 psig) cut-out pressure; factory cut-out pressure set to 115 kPa (17psig); and liquid filled pressure gauge. Unit c/w UL listed power supply adapter with LED power indicator light, 100-240VAC/50-60Hz/1 to 24 VDC, supplied loose for field installation.

Feeder shall be compatible with glycol solutions of up to 50% concentration. Pump shall be capable of running dry without damage. Unit shall be completely assembled.

### OPTIONAL ACCESSORIES :

**MF200-1430** -- Tank Mounting Shelf

**RIA10-1-SAA** -- Low level Alarm Panel c/w Remote Monitoring Dry Contacts and Selectable Audible Alarm

### LIMITED WARRANTY :

The MF200 is warranted against defects in materials and workmanship for one year.

Project \_\_\_\_\_

Consultant Brian Whitehurst

Unit Tag \_\_\_\_\_

Location \_\_\_\_\_

Contractor \_\_\_\_\_

Sales Agent Pexheat.com

SS-SF-200-01