

Available at: 888-470-2757

FT SERIES

PEXHEAT.COM

Residential Hydronic Combination Boiler



Date:

Project #:

Engineer:

Prepared By:

Bid Date:

MFTCW | Wall Mounted Combination

Boiler / Water Heater

Indoor Sizes 140, 199

Submittal Data



Project Name:

Location:

Contractor:

Standard Equipment

- Stainless steel heat exchanger with finned aluminum core fire tubes
- ASME "H" stamp
- ASME 30 psi (207kPa) working pressure
- 95% AFUE
- Full modulation with 10:1 turndown ratio (10-100% of full fire)
- Stainless Steel indirect DHW tank
- DHW priority
- Inlet DHW filter
- Boiler pump wired and mounted
- 30 psi (207kPa) ASME pressure relief valve
- Pressure gauge
- Sealed combustion chamber
- Pre-mix ceramic fiber burner
- Low NOx system exceeds the most stringent regulations for air quality
- Horizontal or vertical direct vent
- Vent and air pipe lengths up to 100 equivalent feet (each)
- Electronic PID modulating control
- Large user-interface and display
- Outdoor reset (sensor included)
- 0-10VDC external setpoint connections
- Manual reset high limit
- Customizable Freeze Protection
- Direct spark ignition
- Gas leak detection
- Built-in condensate trap and drain
- Automatic air vent
- Boiler water pressure switch
- Blocked vent pressure switch
- Blocked condensate pressure switch
- Burner site glass
- Wall mount bracket
- Screens for vent and air pipe
- Propane conversion kit
- 10-Year limited heat exchanger warranty
- 5-Year limited parts warranty

Boiler Data

Number of Units:

Field Installed Accessory Kits

- Piping Manifold Kit
- Neutralizer Kit

Horizontal Concentric Vent/Air Termination

- 2"
- 3"

Concentric Flush-Mount Vent/Air Termination

- 2"
- 3"



Sizing Data

Model	Input		Heating Capacity		Net Rating		Certified AFUE	Gas Conn Size	Heating Conn Size	DHW Conn Size	Shipping Weight	
	MBH	kW	MBH	kW	MBH	kW					lbs	kg
MFTCW140	140	41	129	38	112	33	95.0%	¾" NPT	1" NPT	3/4" NPT	111	50
MFTCW199	199	58	181	53	157	46	95.0%	¾" NPT	1" NPT	3/4" NPT	130	59

NOTES:

1. For other boiler ratings:

Boiler Horsepower: $HP = \frac{\text{Output}}{33,475}$ Radiation Surface: $EDR \text{ sq. ft.} = \frac{\text{Output}}{150}$

Domestic Hot Water Capacity

Model	35°F Rise		45°F Rise		77°F Rise		Stored DHW	
	GPM	l/m	GPM	l/m	GPM	l/m	Gallons	liters
MFTCW140	7.1	27	5.5	21	3.2	12	0.5	1.9
MFTCW199	9.8	37	7.7	29	4.8	18	0.5	1.9

Clearances

Appliance Surface	Clearance from Combustibles and Non-combustible Surfaces	Suggested Service Clearance
TOP	9 in (23 cm)	18 in (46 cm)
BACK	0 in (0 cm)	0 in (0 cm)
FRONT	24 in (61 cm)	40 in (101 cm)
SIDE	3 in (7 cm)	8 in (20 cm)
BOTTOM	12 in (30 cm)	24 in (61 cm)

Electrical Data

Size	Boiler			Max Power Consumption
	Volts	Phase	Amps	
140 and 199	120	Single	4	160W

Minimum 15A circuit required

Vent System

INTAKE / EXHAUST						
Max Equivalent Vent and Air Pipe Length (each)						
SIZES	STANDARD 2-PIPE			STANDARD 2-PIPE		
	DIA.	FT.	m	DIA.	FT.	m
(all sizes)	2"*	50	15.2	3"	100	30.5

* Must use 3x2 adapter within 1ft (30 cm) of boiler. Reference the Installation and Operation Manual for more details.

Dimensional Data

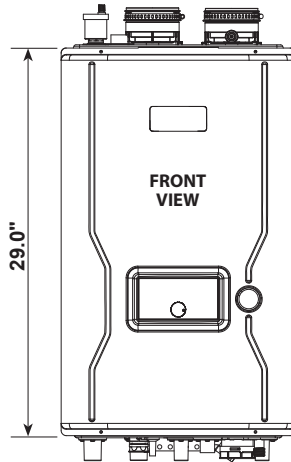
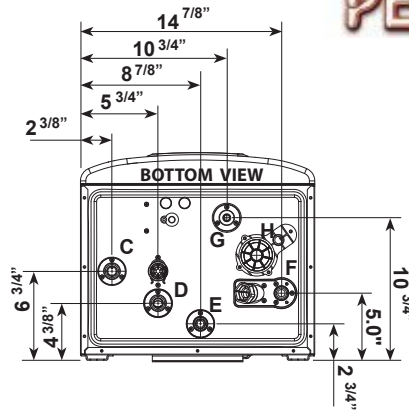
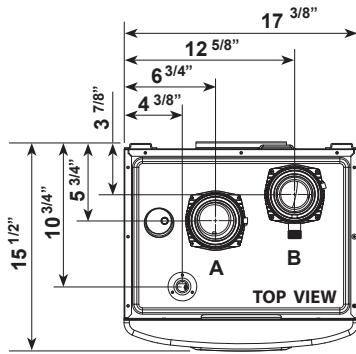

	Description	Diameter
A	Air Intake collar	3"
B	Vent Pipe Collar	3"
C	'CH' Supply	1" NPT
D	'CH' Return	1" NPT
E	'DHW' Outlet	3/4" NPT
F	'DHW' Inlet	3/4" NPT
G	Gas Inlet	3/4" NPT
H	Condensate Line	1/2" NPT

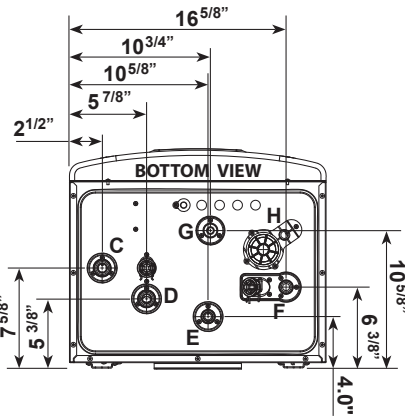
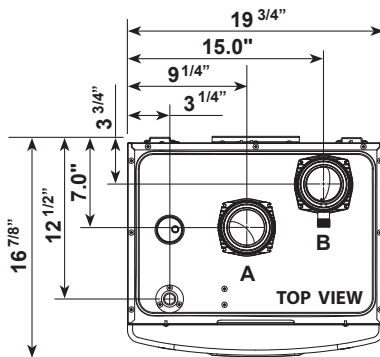

MFTCW199

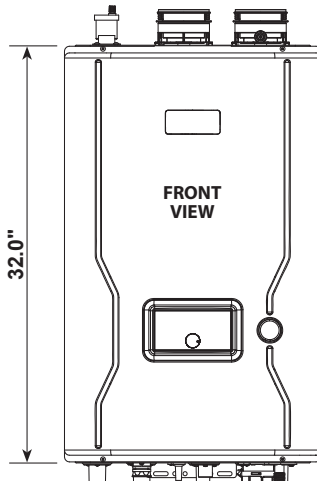

	Description	Diameter
A	Air Intake collar	3"
B	Vent Pipe Collar	3"
C	'CH' Supply	1" NPT
D	'CH' Return	1" NPT
E	'DHW' Outlet	3/4" NPT
F	'DHW' Inlet	3/4" NPT
G	Gas Inlet	3/4" NPT
H	Condensate Line	1/2" NPT

