



521\_C

12/20

Zoning

Replaces: 01/14

# tekmar® Submittal

## Programmable Thermostat 521

Job \_\_\_\_\_ Designer Brian Whitehurst Contact Pexheat.com

The Programmable Thermostat 521 is designed for three different modes of operation: single stage heating, two stages of heating with a fan, or one stage of heating and one stage of cooling with a fan. Two auxiliary sensors may be added to measure the floor, outdoor or room temperature. A Slab Sensor 079 is included to measure floor temperature to protect the floor from overheating and enhance comfort. The programmable schedule supports either a 7 day or 24 hour schedule with 2 or 4 events per day. A permanent temperature hold button overrides the programmable schedule. An optional Adaptor Plate 012 is available to allow the thermostat to mount onto a single gang electrical box.

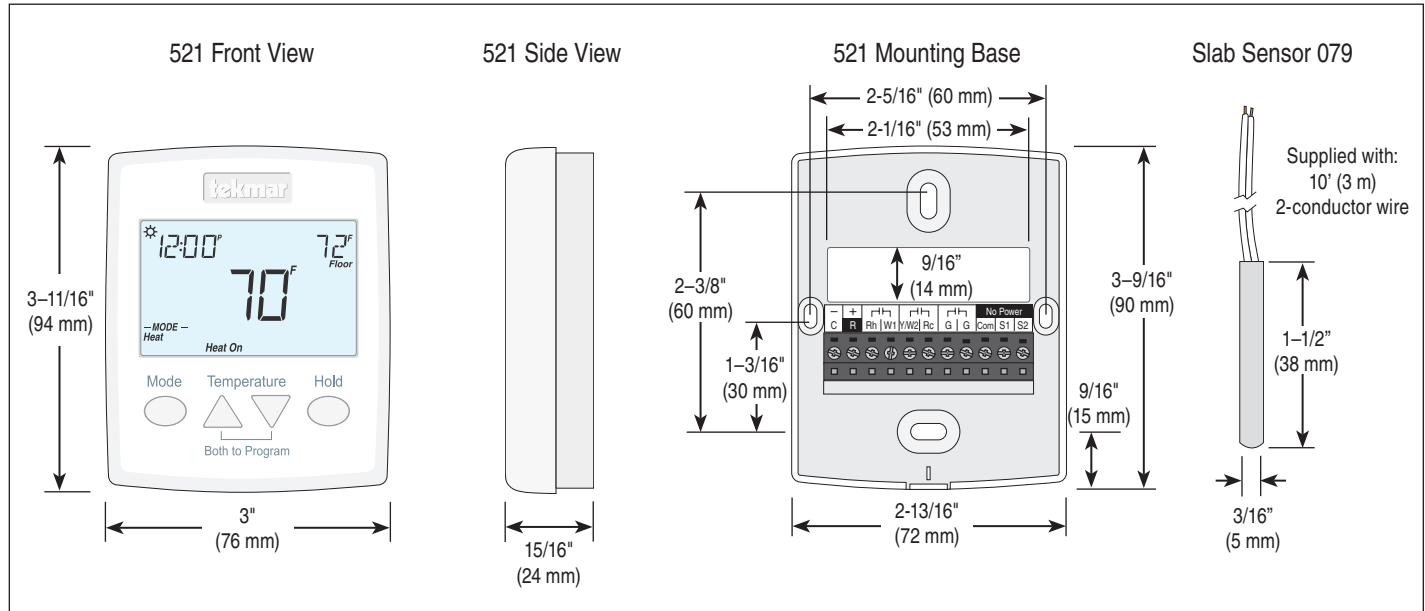

### Specifications

Programmable Thermostat 521 Two Heat or Heat-Cool (Includes Sensor 079)	
Literature	521_A, 521_C, 521_D, 521_Q, 521_U
Control	Microprocessor control. This is not a safety (limit) control
Packaged weight	0.6 lb. (290 g)
Dimensions	3-11/16" H x 3" W x 15/16" D (94 x 76 x 24 mm)
Enclosure	White PVC plastic, NEMA type 1
Approvals	Meets Class B: ICES & FCC Part 15, CE
Ambient conditions	Indoor use only, 32 to 122°F (0 to 50°C), RH ≤90% non-condensing
Power supply	10 to 30 V (ac/dc), 50/60 Hz, 1.8 VA, Class 2
Relays	30 V (ac/dc) 2 A, Class 2 circuits
Sensor	NTC thermistor, 10 kΩ @ 77°F (25°C ±0.2°C) β=3892
-Included	Slab Sensor 079
-Optional	tekmar type # 070, 072, 073, 076, 077, 079, 084
Warranty	Limited 3 Year (See 521_D for full warranty)

### Slab Sensor 079 10' (3 m) wire

Dimensions	3/16" OD x 1-1/2" (5 mm OD x 38 mm)
Enclosure	316 stainless steel, 10' (3 m) 24 AWG, 300 volt PVC insulated Zipcord
Operating range	-58 to 221°F (-50 to 105°C)
Sensor	NTC thermistor, 10 kΩ @ 77°F (25°C ±0.2°C) β=3892

### Energy Saving Features

- 7 Day Programmable Schedule

### Additional Features

- Optimum Start
- Permanent Temperature Hold
- Radiant Floor Heating
- Two Stage Heating
- Cooling
- Fan
- Backlight
- Outdoor and Floor Temperature Display
- Time Clock
- Four Hour Battery-free Clock Backup

Scan code for quick link to product page on [tekmarControls.com](http://tekmarControls.com)



## Sample Application Drawing

Below is a sample application drawing for this product. This application may include other tekmar products that are required for installation. More sample applications can be found at [www.tekmarControls.com](http://www.tekmarControls.com).

### Sample Mechanical diagram

**Legend**

- P1 = Manifold Pump
- S1 = Optional Slab Sensor 079
- T1 = 24 V (ac) Transformer 009
- Z1 = Zone Valve

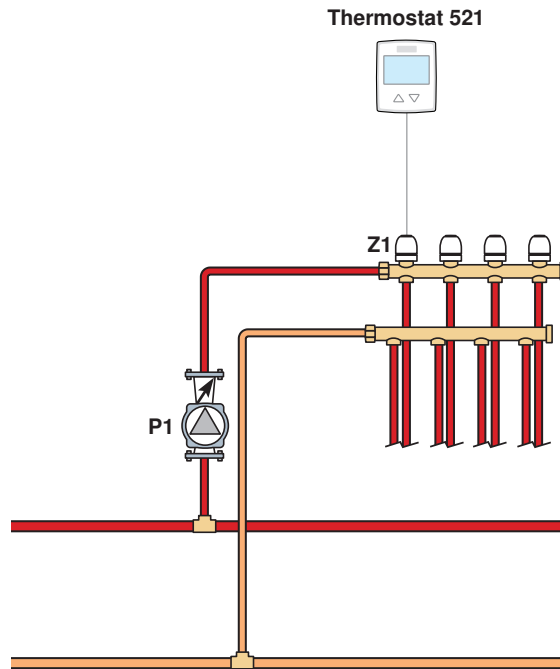

### Sample Electrical diagram

