

HydroMixer™ thermostatic fixed temperature mixing unit

166 series



Function

The 166 series HydroMixer™ provides a fixed temperature flow to low temperature secondary heating circuits (such as floor radiant panels), complete with onboard three-speed or variable-speed pump, thermostatic three-way mixing valve with built-in temperature sensor, check valve, supply and return temperature gauges, secondary circuit shut-off ball valves and pre-formed insulation shell. Versions are available with either the three-speed Grundfos UPS 15-58 pump or the variable-speed Alpha 25-55U pump.

The unit can be ordered with supply flow and pump on the right or left side, and the unit is field reversible to accommodate changing installation requirements. The adjustable differential pressure by-pass valve, code 519600 and wall bracket code 165001 are optional. The unit comes with male union connections which require separately purchased, 1 inch sweat or NPT, top outlet and bottom inlet fitting kits.

Product Range

Code 166600A	Thermostatic fixed temperature mixing unit with Grundfos UPS 15-58 pump on right side.....connections 1" sweat or NPT union*
Code 166610A	Thermostatic fixed temperature mixing unit with Grundfos UPS 15-58 pump on left side.....connections 1" sweat or NPT union*
Code 166602A	Thermostatic fixed temperature mixing unit with Grundfos Alpha 25-55U pump on right side.....connections 1" sweat or NPT union*
Code 166612A	Thermostatic fixed temperature mixing unit with Grundfos Alpha 25-55U pump on left side.....connections 1" sweat or NPT union*

*Fitting sets sold separately

Technical Characteristics

Materials

Three-way thermostatic mixing valve

Body:	brass
Shutter:	PSU
Spring:	stainless steel
Seals:	EPDM

Connecting pipes

Material:	steel
-----------	-------

Check valve

Body:	brass
Shutter:	PPAG40

Shut-off ball valves

Body:	brass
-------	-------

Performance

Suitable fluids:	water, glycol solution
Max. percentage of glycol:	30%
Max. working pressure:	145 psi (10 bar)
Adjustable temperature range:	80–125°F (25–50°C)
Primary inlet max. temperature:	212°F (100°C)

Connections:

	male union threads
- top outlets:	1-1/4" male straight
- bottom inlets:	1-1/2" male straight
- inlet/outlet center distance:	5 inches (125 mm)

Pump

Three-speed pump:	Grundfos: UPS 15-58-130;
Variable-speed pump:	Grundfos: ALPHA 25-55U;
Body material:	cast iron
Power supply:	115 V 50/60 Hz
Protection class:	Class F
Pump center distance:	5-1/8" (130 mm)
Pump connections:	1 1/2" male straight

Temperature gauges

Dual scale:	32 –176°F (0 – 80°C)
-------------	----------------------

Technical specification of insulation

Material:	EPP
Thickness:	1 1/8" (30 mm)
Density:	3 lb/ft ³ (45 kg/m ³)
Working temperature range:	25–250°F (-5–120°C)
Thermal conductivity:	0.037 W/(m·K) at 10°C
Fire resistance (UL94):	class HBF

Adjustable Differential by-pass valve code 519006 (optional)

Body:	brass
Valve plug:	EPDM
Spring:	stainless steel
Seals:	EPDM
Max. working pressure:	145 psi (10 bar)
Max. working temperature:	212°F (100°C)
By-pass differential pressure setting range:	0.3 – 4.3 psi (2 – 30 kPa)
Connections:	1" male x 1" male (straight)

Wall bracket code 165001 (optional)

Material:	stainless steel
-----------	-----------------

Dimensions

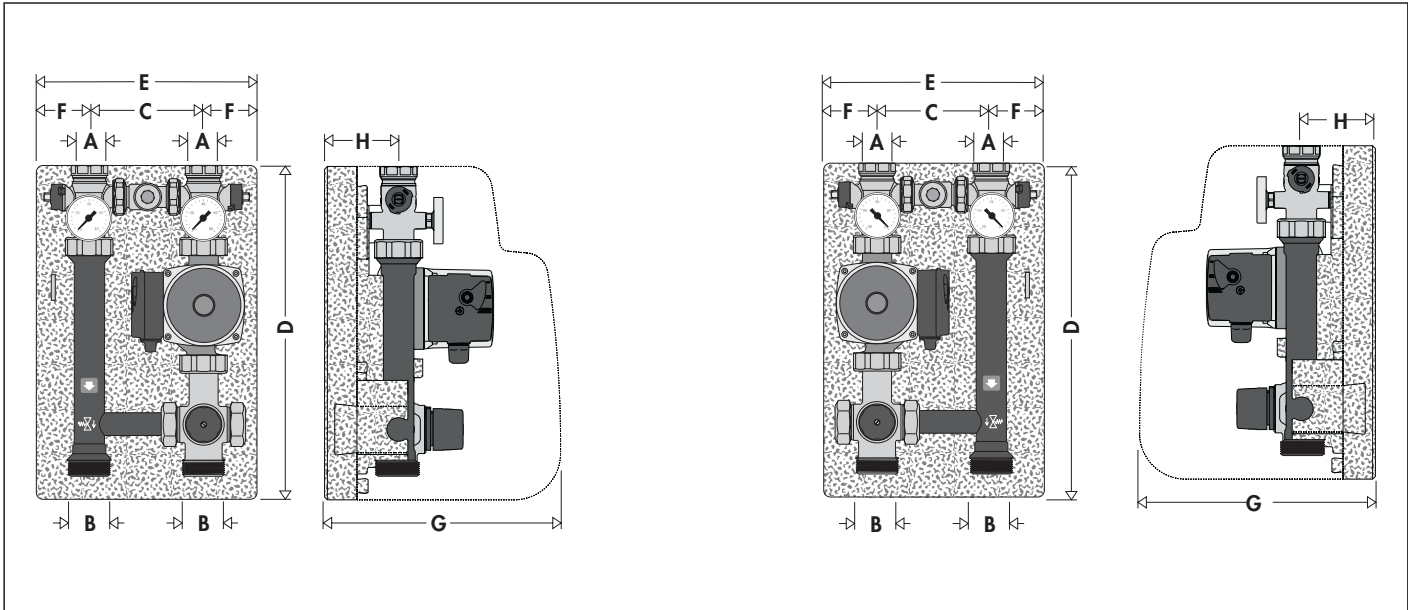

A	B	C	D	E	F	G	H	Weight(lb)
1 1/4"	1 1/2"	5"	14 1/4"	9 3/4"	2 7/8"	10"	3 3/16"	22

Code	Description
166600A	Thermostatic fixed temperature mixing unit with Grundfos 15-58 pump on right
166610A	Thermostatic fixed temperature mixing unit with Grundfos 15-58 pump on left
166602A	Thermostatic fixed temperature mixing unit with Grundfos Alpha 25-55U pump on right
166612A	Thermostatic fixed temperature mixing unit with Grundfos Alpha 25-55U pump on left

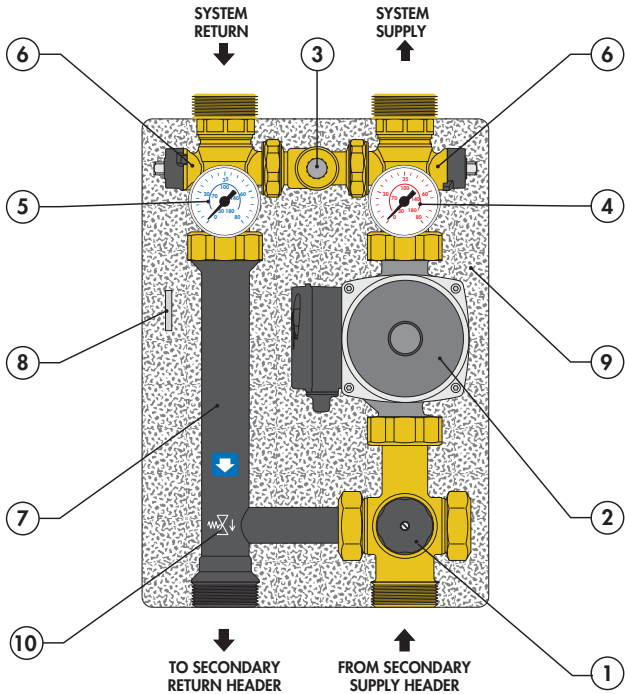

Component Characteristics

- 1 Three-way mixing valve with built-in temperature sensor
 - 2 Variable-speed pump Alpha 25-55U or three-speed UPS 15-58 pump
 - 3 Adjustable differential pressure by-pass valve (optional - shown in view)*
 - 4 Supply temperature gauge
 - 5 Return pressure gauge
 - 6 Secondary circuit shut-off ball valves
 - 7 Connecting pipes
 - 8 Wrench to adjust secondary circuit shut-off ball valves
 - 9 Insulation
 - 10 Check valve
- *Factory set-up includes a blind spacer (no flow path)**

Hydraulic diagram

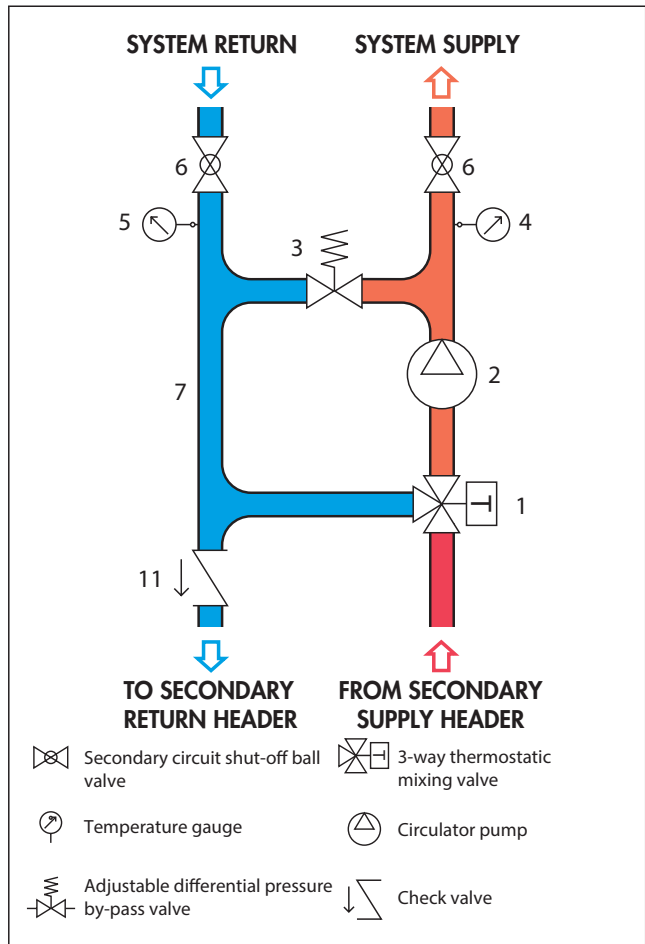

Operating Principle

The fluid temperature is controlled by a thermostatic three-way mixing valve regulated by a thermostatic sensor (1) located in the mixed water outlet chamber (2) of the valve. By expanding and contracting, it continuously ensures a correct proportioning of hot water coming from the boiler, and water returning from the secondary circuit. The water intake is regulated by an internal cartridge, consisting of a piston (5) that slides inside a cylinder, located between the hot water flow (3) and the water returning from the circuit (4). Even if the secondary circuit thermal load or the inlet temperature from the boiler changes, the mixing valve automatically adjusts the flow rate until it obtains the set system flow temperature.

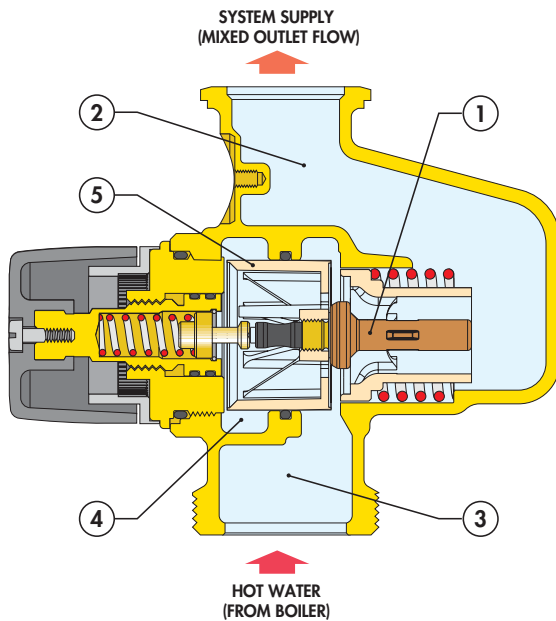

Construction details

Low inertia thermostat sensor

The temperature-sensitive element, the "engine" of the thermostatic three-way valve has low thermal inertia. Therefore, it can quickly react to changes in the conditions of inlet pressure and temperature, shortening the valve response time as the thermal load changes.

Temperature adjustment and locking

The control knob is used to adjust temperature in a full turn (360°) between min. and max. It also has tamper protection for locking the temperature at the set value.

Temperature adjustment

The temperature is set to the required value by means of the knob with the graduated scale, on the top of the valve.

Position	Min	1	2	3	4	5	6	7	Max
T (°F)	70	80	85	95	105	110	115	125	130
T (°C)	22	25	30	35	40	43	46	50	55

with: $T_{\text{boiler}} = 160^{\circ}\text{F}$ (70°C)

Adjustment Locking

Turn the knob to the required number. Unscrew the upper screw and remove the knob. Place the knob back on so that the internal slot mates with the key on the valve body. Reinstall the upper screw.

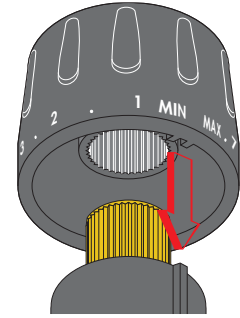

Wall bracket



165001

Wall mounting bracket for 166 series units. Stainless steel.

Bracket installation

The mounting bracket for wall placement must be attached with dowels, using the special holes in the base.

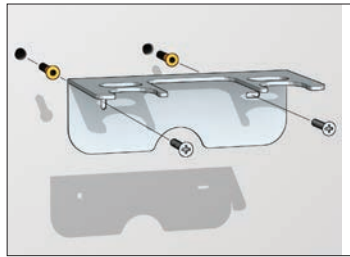

The HydroMixer™ 166 series unit is applied to the bracket using the slots under the hex part of the shut-off ball valves.

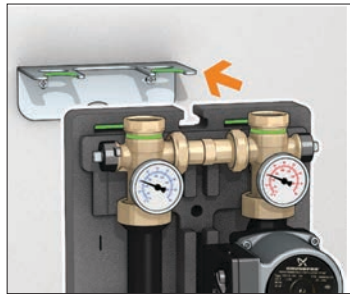

Hydraulic characteristic of code 519006 Differential pressure by-pass valve

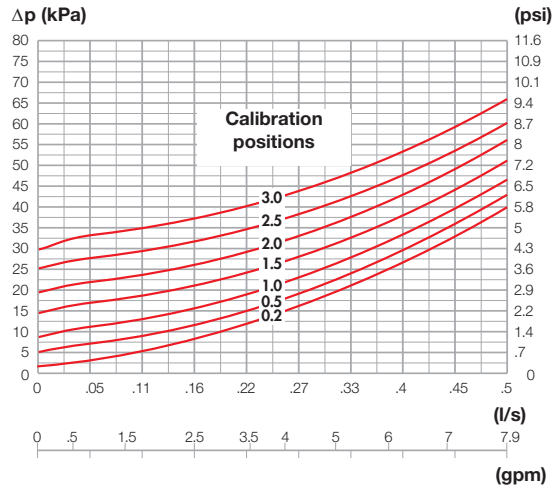

Hydraulic characteristics shown account for the presence of ball valves

Installation of adjustable differential pressure by-pass valve

To mount the differential pressure by-pass valve, insert it in place of the standard spacer. After closing the ball valves using the wrench provided, remove the spacer, as shown in the following figure.

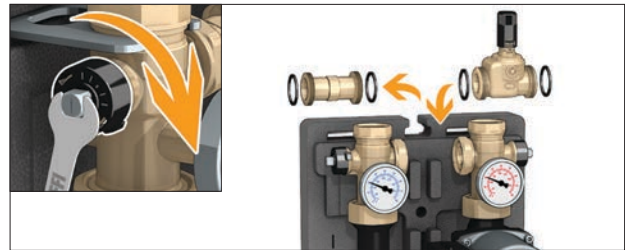

Adjustable differential pressure by-pass valve

519006



Differential pressure by-pass valve for 166 series.

Max. operating pressure: 145 psi (10 bar)

Max. operating temperature: 212°F (100°C)

By-pass differential pressure setting range: 0.3 - 4.3 psi (2 - 30 kPa)

Connections : 1" male x 1" male (straight)

The adjustable differential pressure by-pass valve ensures the head pressure of the pump is proportional to the number of two-way on/off, modulating or thermostatic valves being closed in the secondary circuit, preventing pump overheating and excessive fluid velocity.

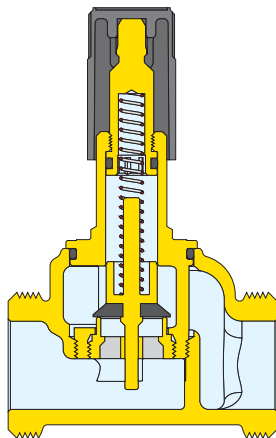

The mounting is different depending on the direction of the discharge flow:

- By-pass valve installed with flow direction as indicated below for unit with pump and upward discharge flow to secondary circuit on the right side:

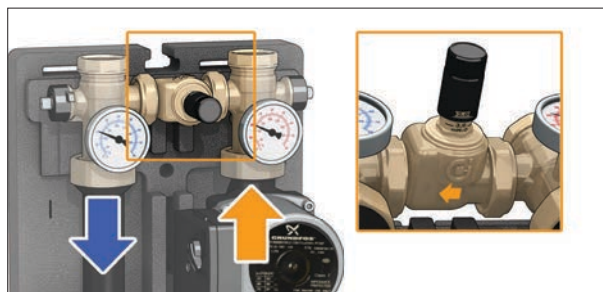

- By-pass valve installed with flow direction as indicated below for unit with pump and upward discharge flow to secondary circuit on the left side:

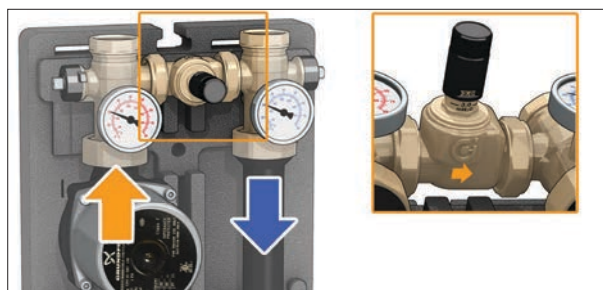

Reversible left-right

The group is assembled at the factory with right side discharge with upward flow, codes 166600A or 166602A, or with left side discharge with upward flow, codes 166620A or 166612A. If not acceptable, or field installation plans have changed, the position of the direction of flow can be switched. Follow the instructions below to switch sides as needed:

1. Remove insulation; front and rear shells.



2. Unscrew the connecting pipes, the shut-off ball valve/spacer and mixing valve assemblies. Remove the pump.



3. Unscrew the cap on the right side port of the mixing valve and screw it on the opposite side.



4. Rotate the connecting pipe 180° relative to its axis.



With UPS 15-58 pump the electronic housing of the pump must be removed by unscrewing the four screws indicated by the arrows and turning the body 90° counterclockwise and reinstalling. Without performing this task, it is not possible to push the group into the insulation. The ALPHA 25-55U pump will fit inside the insulation without any modifications.



5. Reassemble the unit shown in the figure, tightening all union nut connections completely ensuring all seals are retained.



6. Reverse the position of temperature gauges as shown.



7. Move the spacer/insert square on the right.

Note: you can use the recess channel in the center of the insulation for electrical cords.

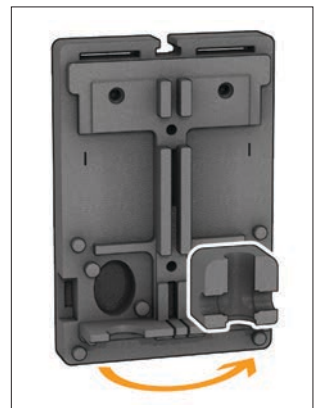

8. Reassemble the insulation.



Accessories



Top outlet fitting set fits 165 series. Includes (2) union nuts, (2) tail pieces and (2) washers. Will not fit bottom inlet thread.

Code	Description
NA16069	1" sweat outlet union fitting



Bottom Inlet fitting set fits 165 series. Includes (2) union nuts, (2) tail pieces and (2) washers. Will not fit top outlet thread.

Code	Description
NA16169	1" sweat inlet union fittings



Top outlet fitting set fits 165 series. Includes (2) union nuts, (2) tail pieces and (2) washers. Will not fit bottom inlet thread.

Code	Description
NA16060	1" NPT M outlet union fitting



Bottom Inlet fitting set fits 165 series. Includes (2) union nuts, (2) tail pieces and (2) washers. Will not fit top outlet thread.

Code	Description
NA16160	1" NPT F inlet union fitting

Application Diagram

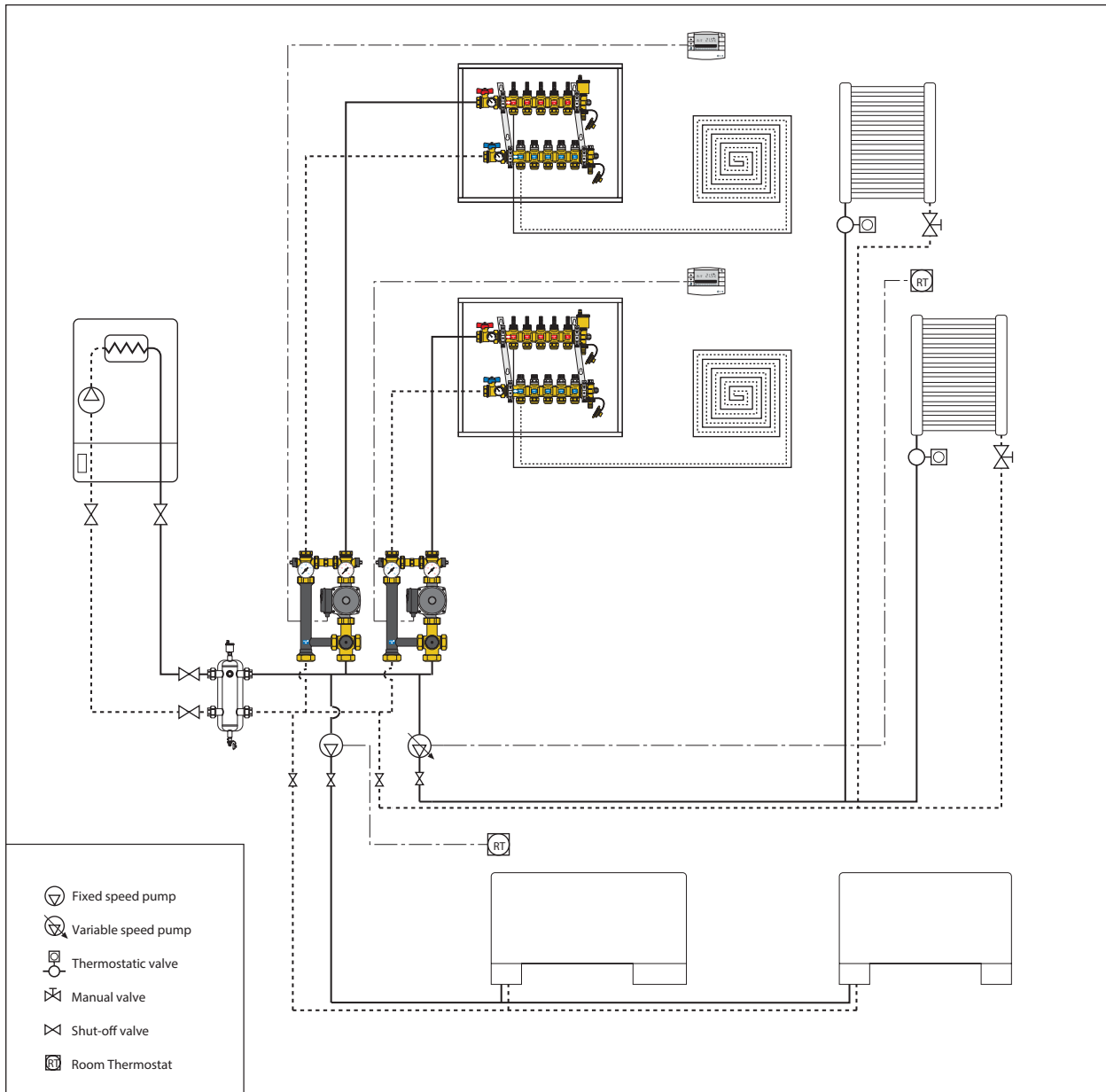

SPECIFICATION SUMMARY

HydroMixer™ 166 series

Thermostatic fixed temperature mixing unit for low temperature heating systems. Factory pre-assembled configurations selectable either with upward flow and discharge (pump mounting) on right side or left side, and field reversible. Union connections to the secondary supply and return header (bottom connections) 1 1/2 " male straight threads. Union connections to the system supply and return circuit (top connections) 1 1/4" male straight threads. Center distance 5" (125 mm) between connections. Adjustable temperature range 80 – 125°F (25 – 50°C). Maximum working pressure 145 psi (10 bar). Complete with Grundfos three-speed pump UPS 15-58 or variable-speed pump Alpha 25-55U, power supply 115 V 50/60 Hz, protection class F. Dual-scale temperature gauges 32 – 176°F (0 – 80°C). Brass secondary circuit shut-off ball valves. Connection pipe in steel. Check valve with brass body, shutter PPAG40. With pre-formed insulation shell in EPP. Provide with 1" sweat or NPT union inlet and outlet fittings, code NA16 series.

Code 519006

Adjustable differential pressure by-pass valve. Brass body. Connections 1" male x 1" male straight threads. Stainless steel spring. Pressure range from 0.3 – 4.3 psi (2 – 30 kPa) . Maximum working pressure 145 psi (10 bar). Maximum working temperature 212°F (100° C).

Code 165001

Mounting bracket in stainless steel.

We reserve the right to change our products and their relevant technical data, contained in this publication, at any time and without prior notice.
